

PMS-LLD020-5040M

Description

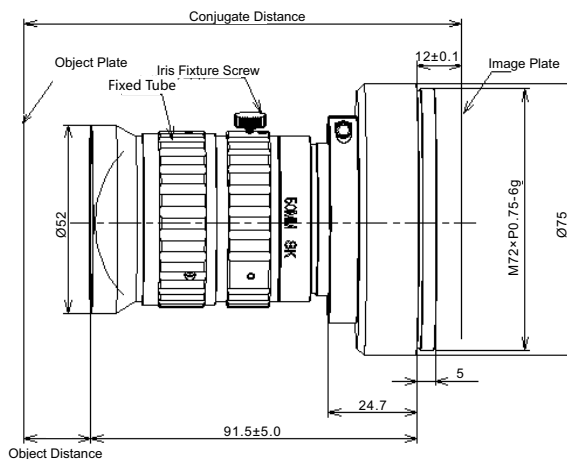
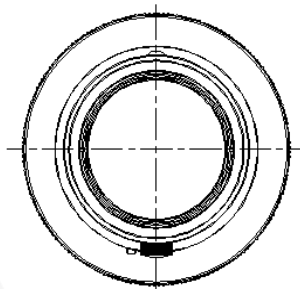

※ The max. sensor $\Phi 62$ mm image, ultra-low distortion, shock-proof design, Standard Mag. range 0.15X ~ 0.25X.

PMS-LLD020-5040M

Parameters

Code	PMS-LLD020-5040M		
Max. FOV (mm)	$\Phi 62$		
Resolution (μm)	5/7		
Standard Mag. (X)	0.15	0.2	0.25
Aperture	4.0~22		
Focus (mm)	50		
Distortion	<0.05%		
Relative Illumination	60%		
Working Distance (mm)	350	265	220
Conjugate Distance (mm)	458.6	381	333.4
Mount	M42/M58/M72/F-Mount		

PMS-LLD020-5040M

Product Case

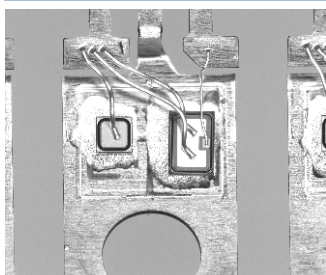

Defect Detection



Surface Pattern And Color Detection

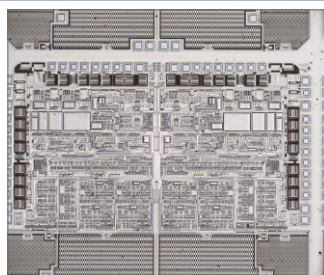

PCB Defect Detection

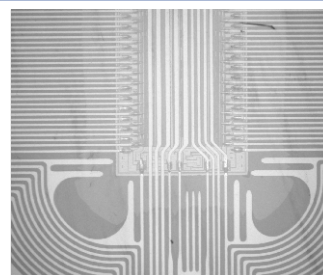

PCB Detection

