

# 12.5X Zoom Lens Series

## PMS-Z125D-C

1. Telecentric optical design. Magnification range: 0.58x-7.5x, magnification ratio is 12.5:1
2. Field of view: 1.47-18.97mm(based on 2/3"CCD)
3. Excellent performance, with high resolution, low distortion and super big N.A.
4. Compact design,easy assembly and installation.



### Function and Feature

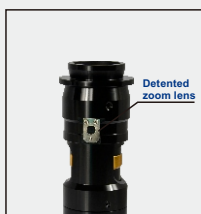

#### ■ Detented Zoom Lens

- High accuracy in zoom and repetitiv positioning
- 15 divided points or 16 divided points for mechanical positioning
- High hardness alloy material, for a long lifespan; Precision mechanical structure





#### ■ Coaxial Illumination

- Infinity parallel incident light, with shadow-free and uniform illumination
- High contract and vivid color image, for better image quality
- Applied for reflective surface observation: waters, polishing samples, deep holes, etc

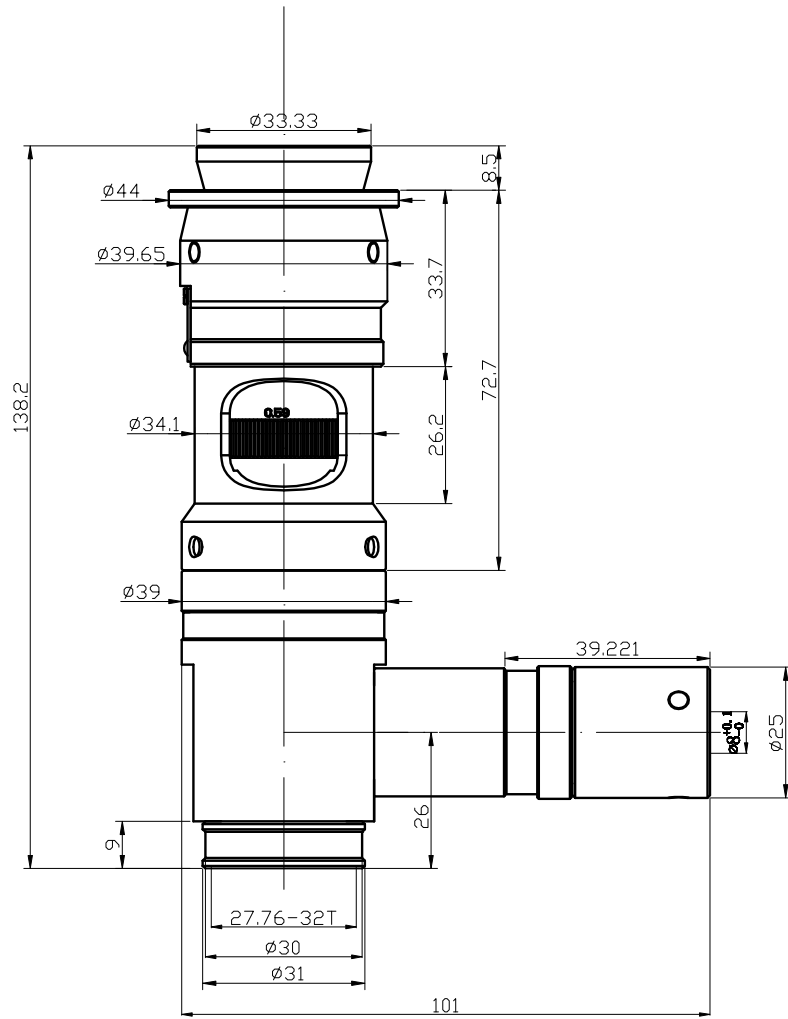
Code		PMS-Z125D-C															
Type		Detented with Coaxial Illumination Zoom Lens															
Optical Magnification Range		0.58X~7.5X															
Working Distance		84 ± 2mm															
Optical Magnification		0.58X	0.6X	1X	1.5X	2X	2.5X	3X	3.5X	4X	4.5X	5X	5.5X	6X	6.5X	7X	7.5X
Depth of View(mm)		2.75	2.67	0.95	0.43	0.27	0.2	0.15	0.12	0.1	0.081	0.073	0.066	0.061	0.056	0.052	0.05
N.A.		0.025	0.025	0.043	0.063	0.074	0.082	0.09	0.097	0.1	0.11	0.11	0.11	0.11	0.11	0.11	0.11
F.No		12.5	12.5	11.85	11.95	13.65	15.3	16.5	18.4	19.9	20.4	22.45	22.7	26.8	29.4	31.7	33.9
Resolution(um)		13	13	7.8	5.3	4.53	4.09	3.73	3.46	3.36	3.05	3.05	3.05	3.05	3.05	3.05	3.05
TV Distortion		0.050%	0.050%	0.002%	0.010%	0.020%	0.003%	0.020%	0.020%	0.018%	0.020%	0.010%	0.010%	0.001%	0.010%	0.005%	0.005%
Field of View (mm)	Diagonal	18.97	18.33	11.00	7.33	5.50	4.40	3.67	3.14	2.75	2.44	2.20	2.00	1.83	1.69	1.57	1.47
	Horizontal	15.17	14.67	8.8	5.87	4.40	3.52	2.93	2.51	2.20	1.96	1.76	1.60	1.47	1.35	1.26	1.17
	vertical	11.38	11.00	6.60	4.40	3.30	2.64	2.20	1.89	1.65	1.47	1.32	1.20	1.10	1.02	0.94	0.88
Max. Sensor Size		2/3"															
Mount		C-Mount															
Zoom Control		Manual Zoom															
Focus Control		--															



Unit:mm	Scale	1:1
 	Name	PMS-Z125D-C
0.0 inch 1.0	Date	2012.2.21
0.0 mm 25.0	<b>POMEAS</b>	