

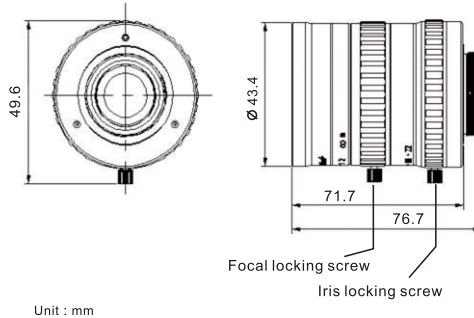

# Pomeas 5 Mega Pixels FA/Machine Vision Lens **PMS-75MC5M**

<b>2/3"</b>	<b>5 Mega</b>	<b>MANUAL</b>	<b>C-mount</b>	<b>METAL</b>
Max. Sensor Size	5 Mega Pixels	Manual Iris	C-mount	Metal Material



- 1.Support 5 MP 2/3" camera
2. Focus and iris locking screw to ensure stable focusing
3. Low imaging distortion
4. Compact structure,excellent optical performance

<b>Code</b>	PMS-75MC5M	
<b>Resolution</b>	5 MP;160lp/mm (center) 125lp/mm (corner)	
<b>Focal Length</b>	75mm	
<b>Iris Range</b>	F2.0-F22	
<b>Max. Sensor Size</b>	2/3" (8.8mm X 6.6mm $\phi$ 11mm)	
<b>Field of View</b> (Diagonal x Horizontal x Verticle)	2/3"	8.4°x6.7°x5.0°
	1/2"	6.1°x4.9°x3.7°
<b>Focusing Range</b>	0.9m- $\infty$	
<b>Object Dimensions</b>	123.2mm X 98.5mm X 73.9mm	
<b>Control</b>	<b>Focus</b>	Manual
	<b>Iris</b>	Manual
<b>Distortion</b>	2/3"	0.04%@y=5.5mm
	1/2"	0.02%@y=4.0mm
<b>Back Focal Length(in air)</b>	13.76mm	
<b>Mount</b>	C-mount	
<b>Filter Thread</b>	M40.5x0.5mm	
<b>Working Temperature</b>	-10°C ~ +50°C	
<b>Weight</b>	223.0g	